

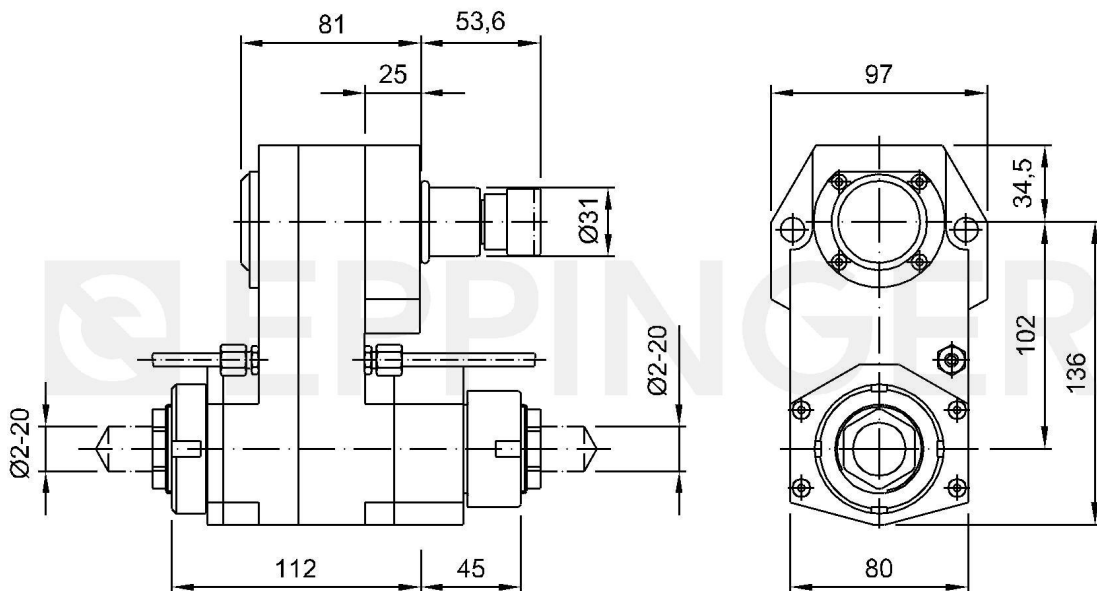

**Drilling and milling head, straight, left hand-right hand, offset, X-axis 11°  
collet chuck, ER32A, external coolant supply**

<b>Part Number</b>	<b>7.070.230</b>
<b>for</b>	<b>Biglia B501/B1000</b>
Ratio	1:1
rpm at Input	max. 4000 rpm
rpm at Output	max. 4000 rpm
Torque at Output	max. 40 Nm
Scope of Delivery	supplied with wrench, excluding collets
Accessories	Collets see Equipment for Toolholders Z2.1 Cover for internal coolant 1088334



Technical Data Subject to Change

07.12.1999 | 06.09.2012