



Drilling and milling head, angular, left hand collet chuck, ER32A, PRECI-FLEX®, external coolant supply

Part Number 4.200.959
for Haas SL/ST40 (130,25 mm)

Ratio 1:1
rpm at Input max. 6000 rpm
rpm at Output max. 6000 rpm
Torque at Output max. 40 Nm
Direction of Rotation 
Scope of Delivery without wrench and collets
*** Actual size inscribed on the tool**



Accessories Collets see Equipment for Toolholders Z2.
Wrench for spindle 0.000.349
PRECI-FLEX® Adapter
Spindle cover see P99.1

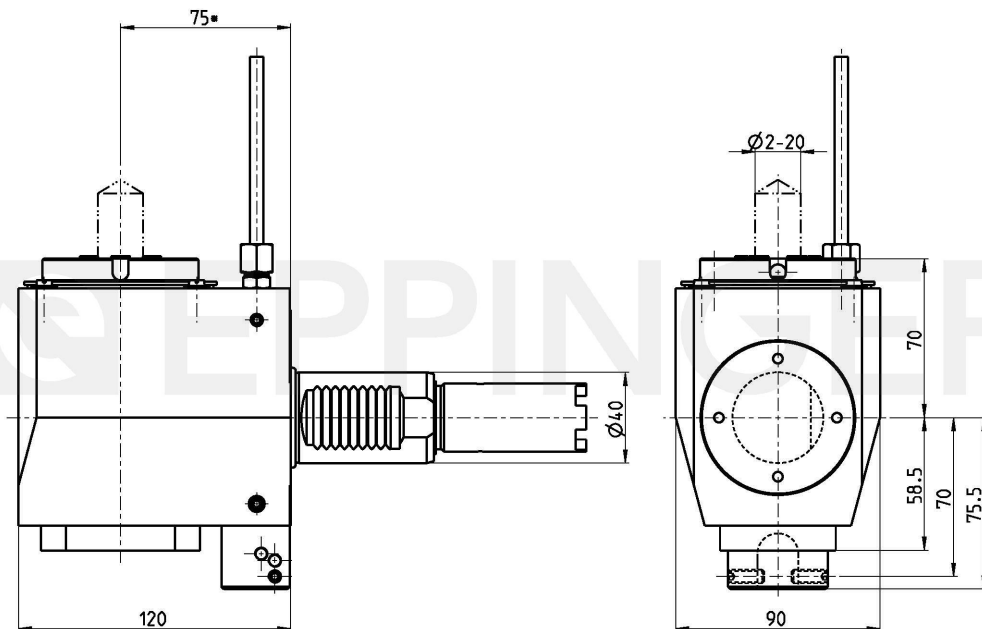

Technical Data Subject to Change

20.10.2003 | 26.01.2015