

## Drilling and milling head, angular, left hand - right hand collet chuck, ER40A, PRECI-FLEX® external and central coolant supply

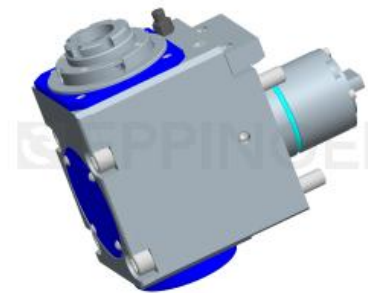

**Part Number** 7.073.395  
**for** Okuma LB/LU4000EX

Ratio 1:1  
rpm at Input max. 6000 rpm  
rpm at Output max. 6000 rpm  
Torque at Output max. 100 Nm  
Direction of Rotation   
Scope of Delivery without wrench and collets  
**\* Actual size inscribed on the tool**



Accessories Collets see Equipment for Toolholders Z2.1  
Sealing washers see Equipment for Toolholders Z4.1  
Wrench for spindle 0.002.277, 10006  
PRECI-FLEX® Adapter  
Spindle cover see P99.1  
Spindle sealing see P99.1  
Coolant tubes 0.000.378

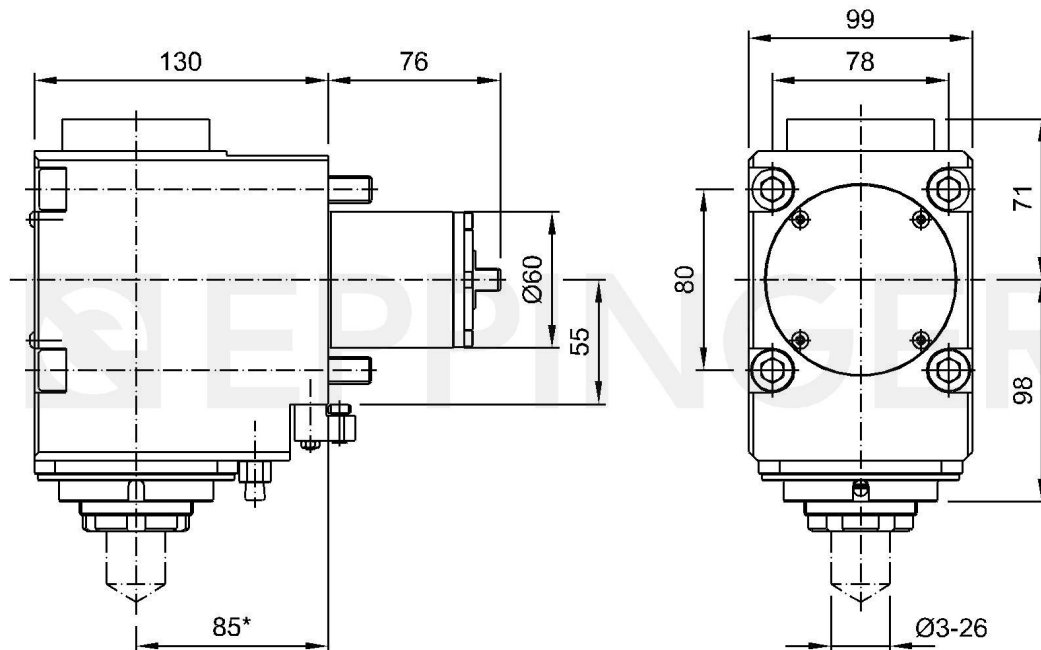

Technical Data Subject to Change

03.07.2007 | 17.09.2012