

Drilling and milling head, angular, short adjustable alignment pin collet chuck, ER25A, PRECI-FLEX®, CC, external and central coolant supply



Part Number 7.076.065
for Takamaz XY 2000

Ratio **1:1**
 rpm at Input **max. 6000 rpm**
 rpm at Output **max. 6000 rpm**
 Torque at Output **max. 40 Nm**
 Direction of Rotation 
 Scope of Delivery **without wrench and collets**

Accessories Collets see Equipment for Toolholders Z2.1
 Sealing washers see Equipment for Toolholders Z4.1
 Wrench for spindle 0.002.277, 15562
 PRECI-FLEX® Adapter
 Spindle cover see P99.1
 Coolant tubes 0.000.377

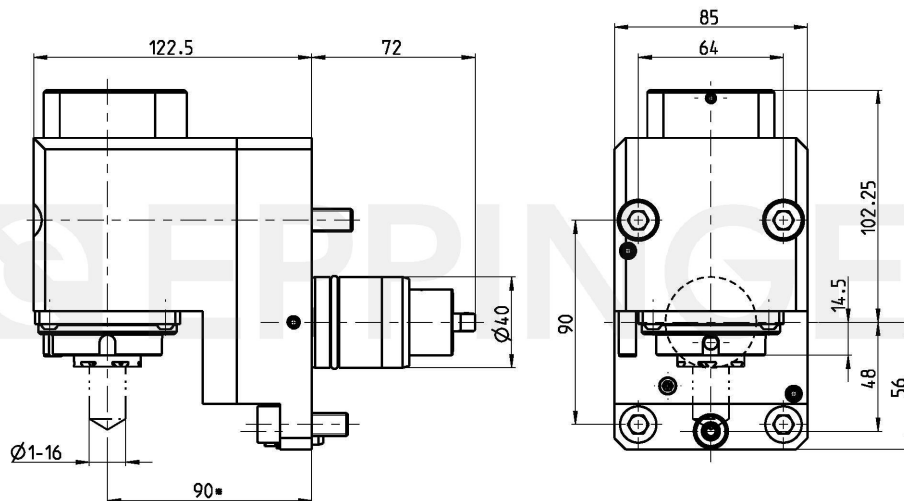
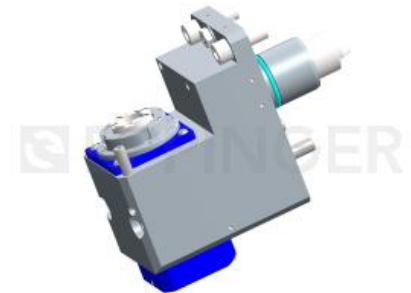

Technical Data Subject to Change

31.01.2012 | 25.02.2013