

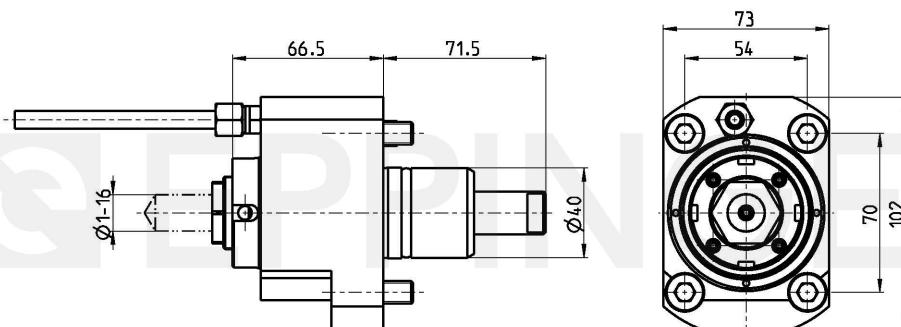

Drilling and milling head, straight collet chuck, ER25A, PRECI-FLEX®, external coolant supply

Part Number 7.170.406
for Murata-Muratec MT12/200

Ratio **1:1**
rpm at Input **max. 4500 rpm**
rpm at Output **max. 4500 rpm**
Torque at Output **max. 25 Nm**
Direction of Rotation 
Scope of Delivery **without wrench and collets**
Accessories Collets see Equipment for Toolholders Z2.
Wrench for spindle 10006
PRECI-FLEX® Adapter
Spindle cover see P99.1



Technical Data Subject to Change

20.06.2016 | 08.09.2016