

**Drilling and milling head, straight
collet chuck, ER25A, PRECI-FLEX®, CC
external coolant supply**

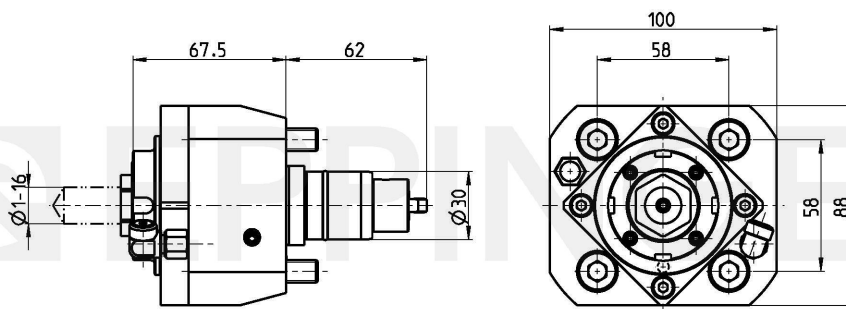

Part Number **7.076.982**
for **Takamaz XB-1000/XY-120 Plus**

Ratio **1:1**
rpm at Input **max. 6000 rpm**
rpm at Output **max. 6000 rpm**
Torque at Output **max. 30 Nm**
Direction of Rotation 
Scope of Delivery **without wrench and collets**
Accessories Collets see Equipment for Toolholders Z2.
Wrench for spindle 0.002.277
PRECI-FLEX® Adapter
Spindle cover see P99.1

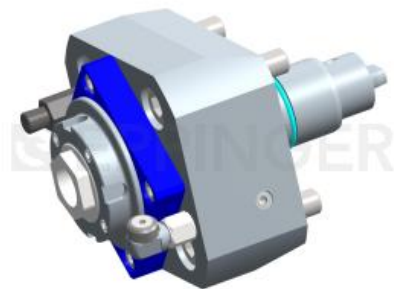

Technical Data Subject to Change

30.08.2016 | 30.08.2016